

REVISION HISTORY				
ZONE	REV	DESCRIPTION	DATE	CHK
	A	RELEASED PER ECN 1060490		
	B	UPDATED RECEIVER: ECN 1080363	1/15/14	DA

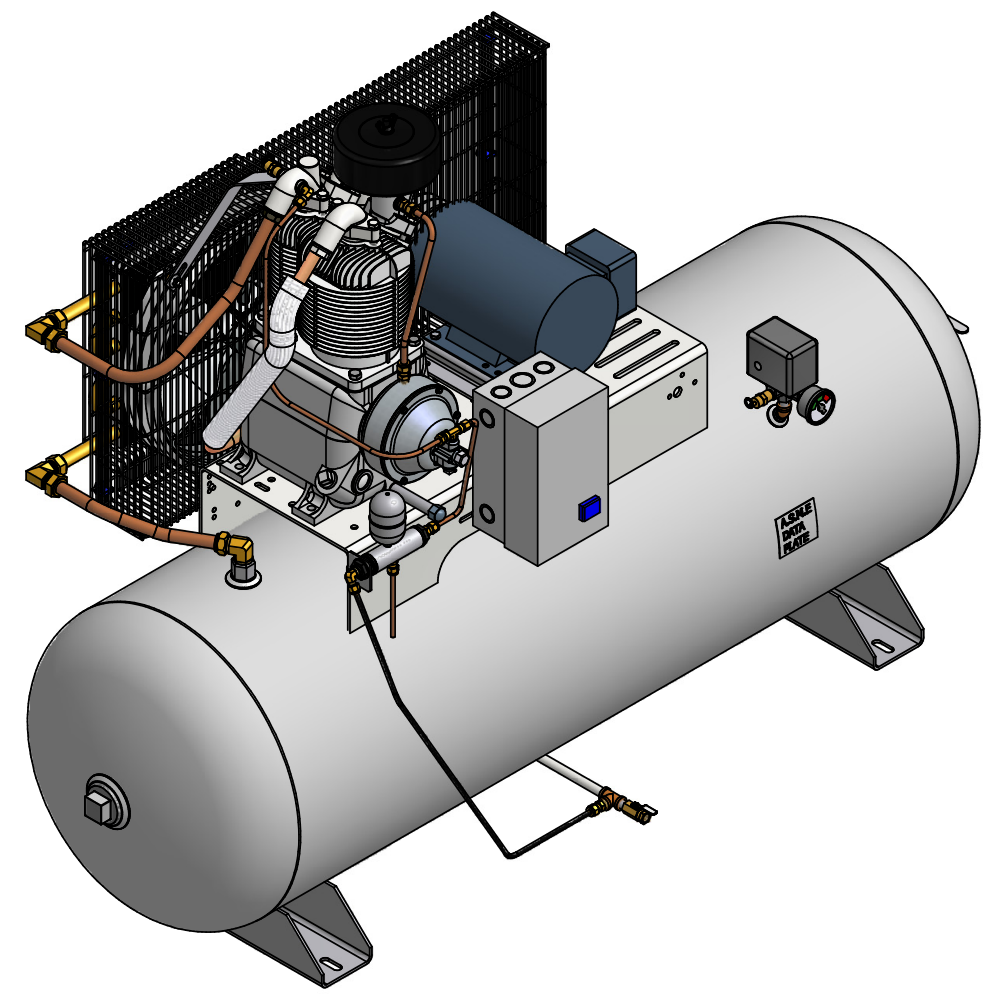
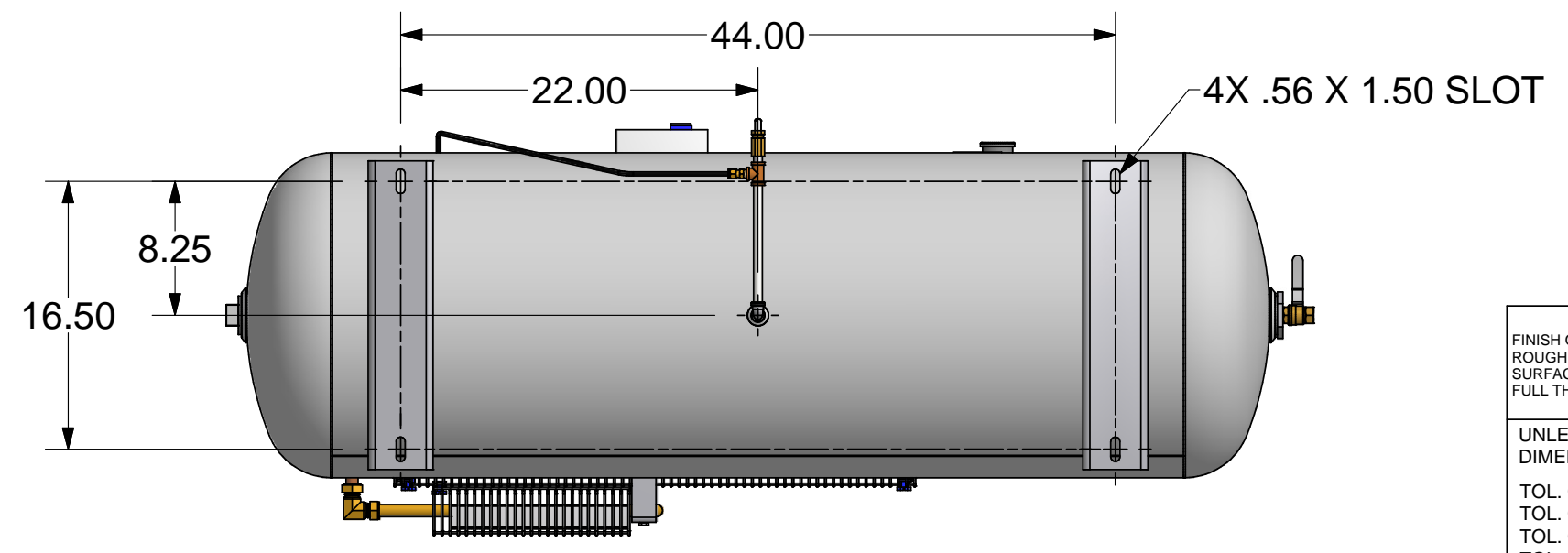
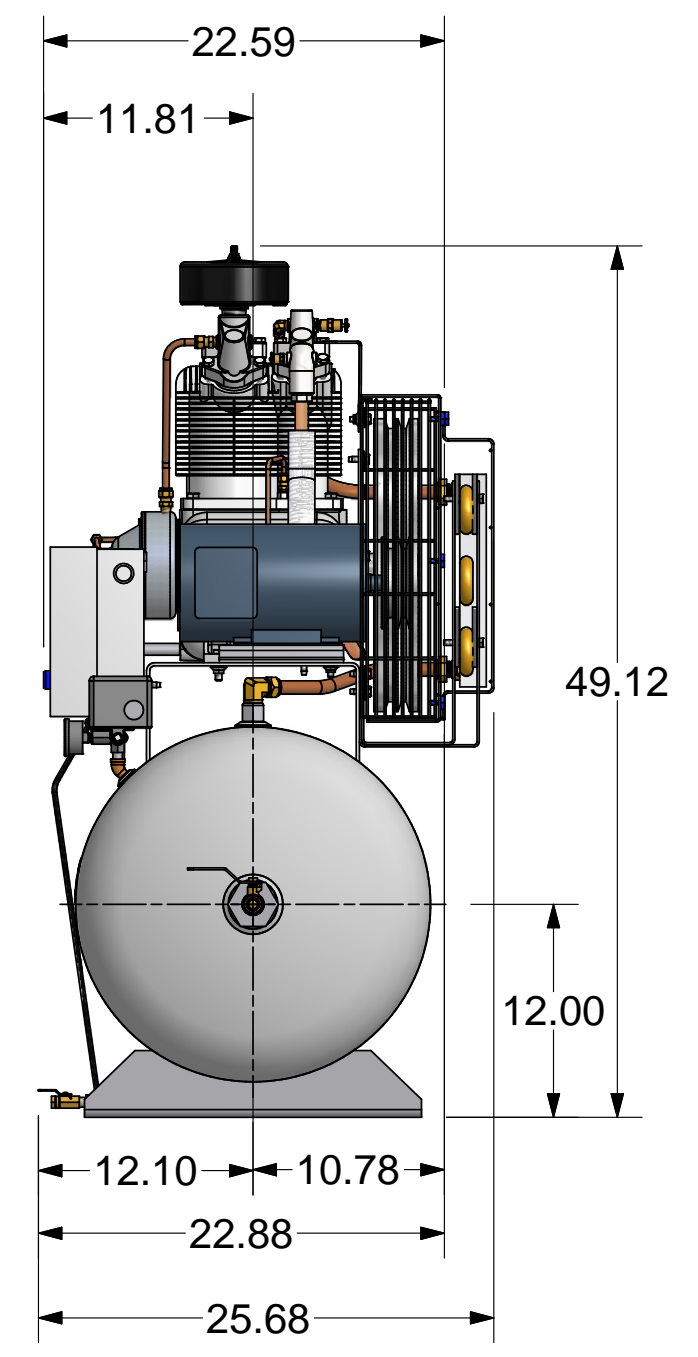
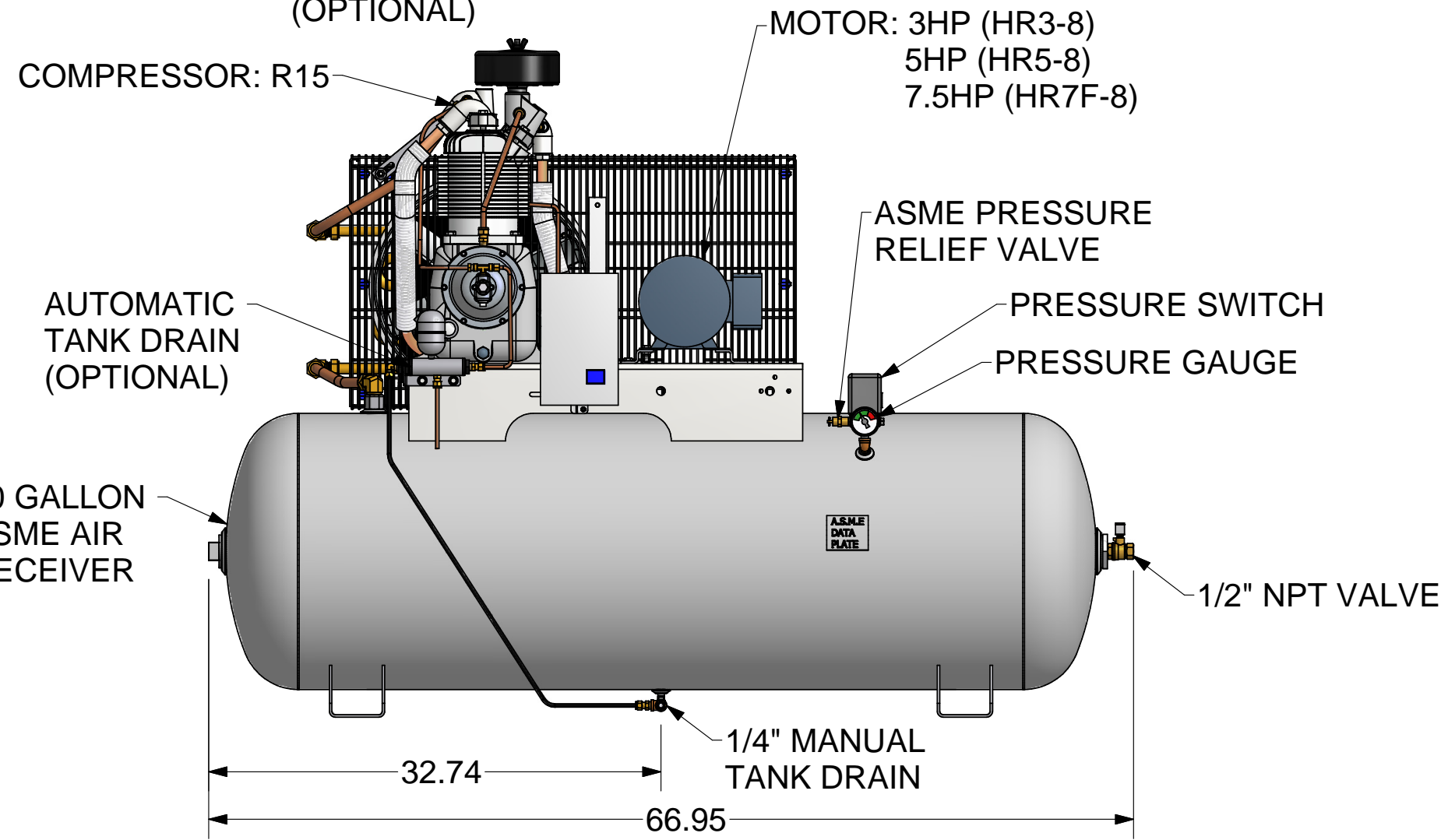
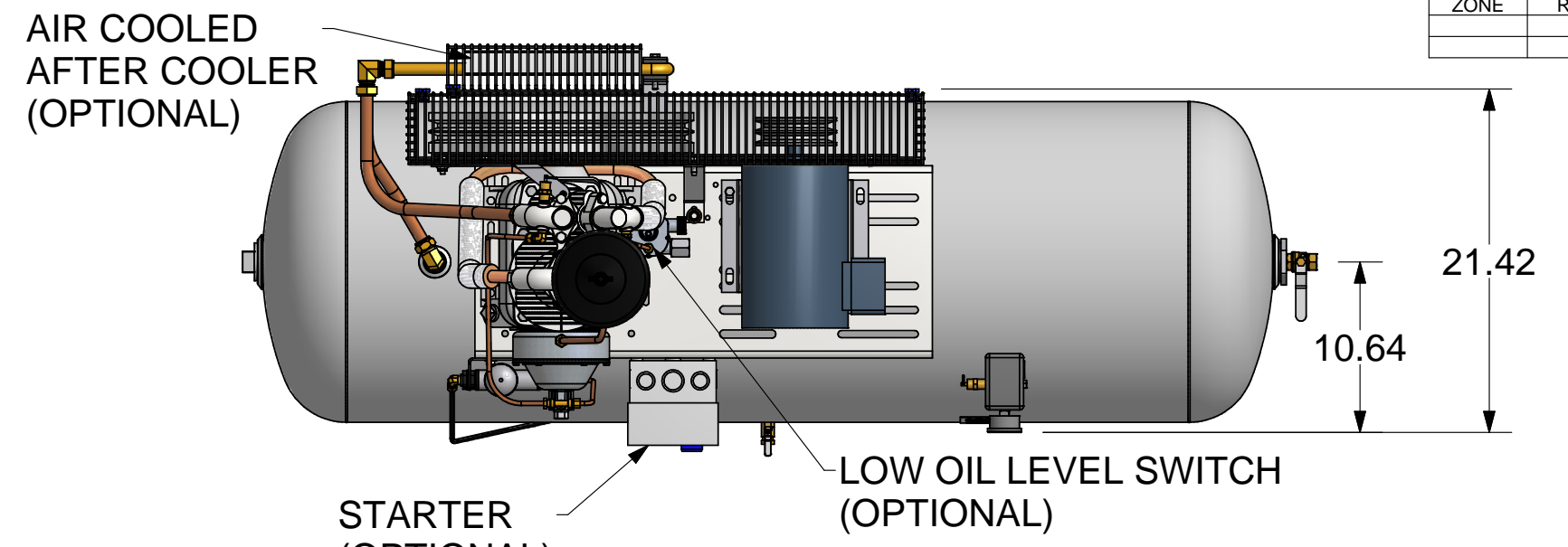

FINISH OF CHAMFERS AND FILLETS TO CONFORM TO ROUGHEST ADJACENT AREA. SURFACE ROUGHNESS MAXIMUM PER ASME B46.1. FULL THREAD DEPTHS ARE MINIMUM.		CONFIDENTIAL - THE INFORMATION CONTAINED IN THIS DOCUMENT IS THE PROPERTY OF GARDNER DENVER, INC. IT IS NOT FOR PUBLIC DISCLOSURE. POSSESSION OF THE INFORMATION DOES NOT CONVEY ANY RIGHT TO LOAN, SELL OR DISCLOSE THE INFORMATION. UNAUTHORIZED REPRODUCTION OR USE OF THE INFORMATION IS PROHIBITED. THIS DOCUMENT IS TO BE RETURNED TO GARDNER DENVER, INC. UPON THE COMPLETION OF THE PURPOSE FOR WHICH IT IS LOANED OR UPON REQUEST.	
UNLESS OTHERWISE SPECIFIED DIMENSIONS ARE IN INCHES		DIMENSIONING AND TOLERANCING PER ASME Y14.5-2009 THREADS PER ASME B1.1 GAGING SYSTEM 21 U.O.S., ANSI B1.20.1 & B1.20.3	
TOL. ON DECIMALS: .X = ± .05 TOL. ON DECIMALS: .XX = ± .02 TOL. ON DECIMALS: .XXX = ± AS SPECIFIED TOL. ON ANGLES: ± 0°-30'		Gardner Denver HEAT TREATMENT ENG. REF:	
THIRD ANGLE PROJECTION		TITLE OUTLINE DRAWING	
Gardner Denver Inc. Quincy, IL.		HR3-8, HR5-8, HR7F-8	
DWN BY KWT 6/14/2011		REV	
CKD BY DA 6/14/2011		DA	
SCALE 1/7		320CAS800	
SHEET 1 OF 1		REV B	